

Opti:Manufacturing

Aerospace Instruments Company



T60 Series

Operation and Service
Manual for Tensiometer



TABLE OF CONTENTS

INTRODUCTION AND DESCRIPTION	2
1-1. INTRODUCTION	2
1-2. PURPOSE -	2
1-3. DESCRIPTION -	2
1-4. WARRANTY -	2
Table 1- Type Identification	2
SPECIAL SERVICE TOOLS	3
2-1. SPECIAL SERVICE TOOLS	3
PREPARATION FOR USE, STORAGE, and SHIPMENT	3
3-1. PREPARATION FOR USE	3
3-2. PERFORMANCE -	3
3-3. STORAGE	3
3-4. SHIPMENT -	3
Figure 1.1- Wrist Band	3
Figure 1- Cable Tensiometer, Typical	4
SECTION IV	4
OPERATION INSTRUCTIONS	4
4-1. GENERAL INSTRUCTIONS	4
4-2. OPERATING INSTRUCTIONS -	5
4-3. MEASURING CABLE DIAMETERS	5
Figure 2- T60 Cable Diameters	5
4-4. TAKING CABLE TENSION READINGS, TYPE C8	6
Figure 3- Preset Instructions, Type C8	6
4-5. TAKING TENSION READINGS, TYPE C9 -	7
Figure 3.5- Preset Instructions, Type C9	7
4-6. DIFFICULT LOCATIONS	7
4-7. ACCURACY -	7
Table 2- T60 Accuracy Tolerance	7
4-8. TYPE OF CABLE -	8
4-9. USE OF CALIBRATION BAR -	8
Figure 4- Calibration Bar Instruction	8
4-10. OVERLOAD -	8
SECTION V	9
PERIODIC INSPECTION, MAINTENANCE, AND LUBRICATION	9
5-1. GENERAL -	9
Table 3- Lubrication Chart	9
SECTION VI	9
TROUBLE SHOOTING	9
6-1. GENERAL -	9
6-2. SERVICE TROUBLES AND REMEDIES -	9
Table 4- Trouble Shooting Chart	9
SECTION VII	10
CALIBRATION	10
7-1. EQUIPMENT REQUIRED -	10
7-2. DISASSEMBLY PRIOR TO CALIBRATION -	10
7-3. CALIBRATION -	10
7-4. INDICATOR CABLE SIZE -	11
Table 5- STD Cable Size to British (CWT) Cable Size Equivalents	11
SECTION VIII	12
GROUP ASSEMBLY PARTS LIST	12
Figure 6- Cable Tensiometer, Type C8 and C9	12
Table 6 Part List	13

SECTION I

INTRODUCTION AND DESCRIPTION

- 1-1. INTRODUCTION** - This publication is issued as the basic Manual of Operation and Service Instructions for Types C8 and C9 Cable Tensiometers manufactured by OPTI Manufacturing Corp., Luquillo, Puerto Rico USA. The equipment covered are listed in table 1. Instructions contained in this publication apply to both types listed, unless specifically noted otherwise.
- 1-2. PURPOSE** - The cable Tensiometer are designed for use in accurate rigging of airborne control cables. In accordance with good rigging and maintenance practices, all rigging equipment and hardware should be inspected periodically for wear, abuse and general adequacy. This Tensiometer shall be calibrated yearly for best accuracy.
- 1-3. DESCRIPTION** - Used extensively, it is considered the standard of the industry in many countries, and has proven it's durably under long and continual service. Each instrument is suitable for use over a wide range of tension measurements and different cable sizes. Firm positive 3-point cable grip prevents dislodgement when instrument hanging free on control cable. The T60 requires no alternate riser for the various size cables. There are no losable parts in the T60. The instrument is always ready for instant use. An easy to operate, accurate, built-in gage eliminates guess work as to size of cable to be tested. Simple, comfortable lever grip permits one hand operation without operator fatigue. In severe cold, service mittens or gloves may be worn without any loss efficiency of operation. A simple lock holds dial pointer at exact reading on cables in areas where instrument cannot be seen. A touch unlocks the pointer preparatory for the next reading. Large, clear numerals make readings easy and accurate. Bezel is easily turned to the correct zero setting for the proper cable size, determined by the gage in the handle head. The T60 is a durable precision instrument and is not damaged by use on cable tensions beyond its range. The cable Tensiometer is a hand-held instrument. A jaw is located at the top of instrument. Actual contact on the cable is made by the riser block and the two sectors located in the jaw. A sliding yoke slides up the frame of the instrument to provide a measuring force. A dial indicator is located at the bottom of the instrument to give the actual tension indication. An actuating handle is pivoted at the center of the instrument and is motivated by a trigger spring within the body of the Tensiometer. A pointer lock button is situated just above the dial indicator and a handle latch is located on the left side of the frame to engage the detent notch of the actuating handle. (See figure 1)
- 1-4. WARRANTY** - The T60 cable Tensiometer has a warranty to the original customer for a period of (1) one year on *new* units and (6) six months for *repaired* units from the invoice date. This warranty is to ensure the cable Tensiometer is free of defects in materials and workmanship under correct and normal use. The warranty can be void if the unit has been tampered, altered, dropped or damaged by an accident. ***The shipping costs to and from OPTI Mfg Corp, are not included in the warranty coverage.***

All returns must have a Return Material Authorization (RMA) number. In order to obtain a RMA, please contact our Quality Department via email, jorge@optimanufacturing.com, or via fax: (787) 889-2805.

Table 1- Type Identification

TYPE	MFR'S PART NUMBER	CABLES	RANGE
Type C8	T60-1001-C8-1A	1/16", 3/32", 1/8"	10 to 200 lbs.-tension
		5/32", 3/16"	30 to 200 lbs.-tension
		7/32", 1/4"	80 to 200 lbs.-tension
British	T60-1002-C8-00	3 CWT, 5 CWT, 10 CWT	10 to 200 lbs.-tension
		15 CWT, 25 CWT	30 to 200 lbs.-tension
		35 CWT, 45 CWT	80 to 200 lbs.-tension
Type C9	T60-1001-C9-1A	1/8", 5/32", 3/16", 7/32", 1/4"	150 to 450 lbs.-tension
British	T60-1002-C9-00	10CWT, 15CWT, 25CWT, 35CWT, 45CWT	150 to 450 lbs.-tension

SECTION II

SPECIAL SERVICE TOOLS

- 2-1. SPECIAL SERVICE TOOLS** - No special tools are required for service or maintenance of the cable Tensiometer.

SECTION III

PREPARATION FOR USE, STORAGE, and SHIPMENT

- 3-1. PREPARATION FOR USE** - The cable Tensiometer is shipped by the manufacturer in its own carrying case and is ready for use, for avoid damage on common use, the operator shall be use the Wrist Band adjustable, see figure 1.1. Each time the cable Tensiometer is used it shall be removed from the case and the serial number stamped on the nameplate checked against the serial number on the tab of the calibration bar.
- 3-2. PERFORMANCE** – The Tensiometer shall be capable for use under extreme conditions of heat or cold without affecting the accuracy of readings, the operating temperature range are -65°F to 160°F (-53°C to 71°C.)
- 3-3. STORAGE** - When the cable Tensiometer is not in use it must be placed in its carrying case. There are no special instructions or precautions relative to storage.
- 3-4. SHIPMENT** - If the cable Tensiometer is to be shipped, it shall be placed in its carrying case and packed in such a manner as to avoid damage by common carrier.

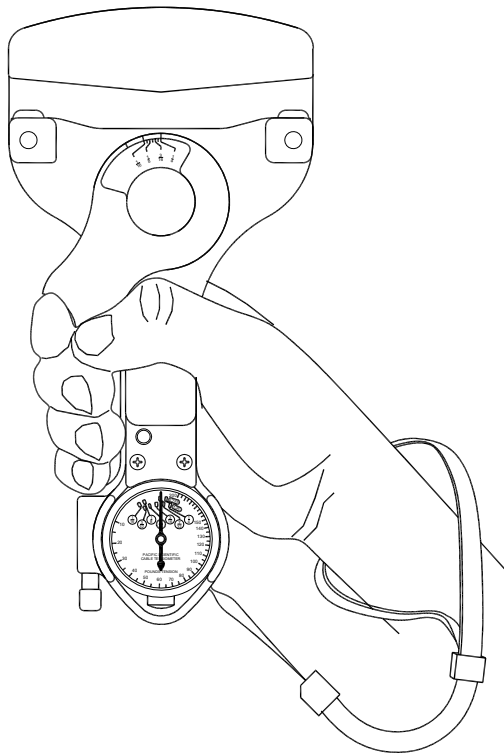

Figure 1.1- Wrist Band

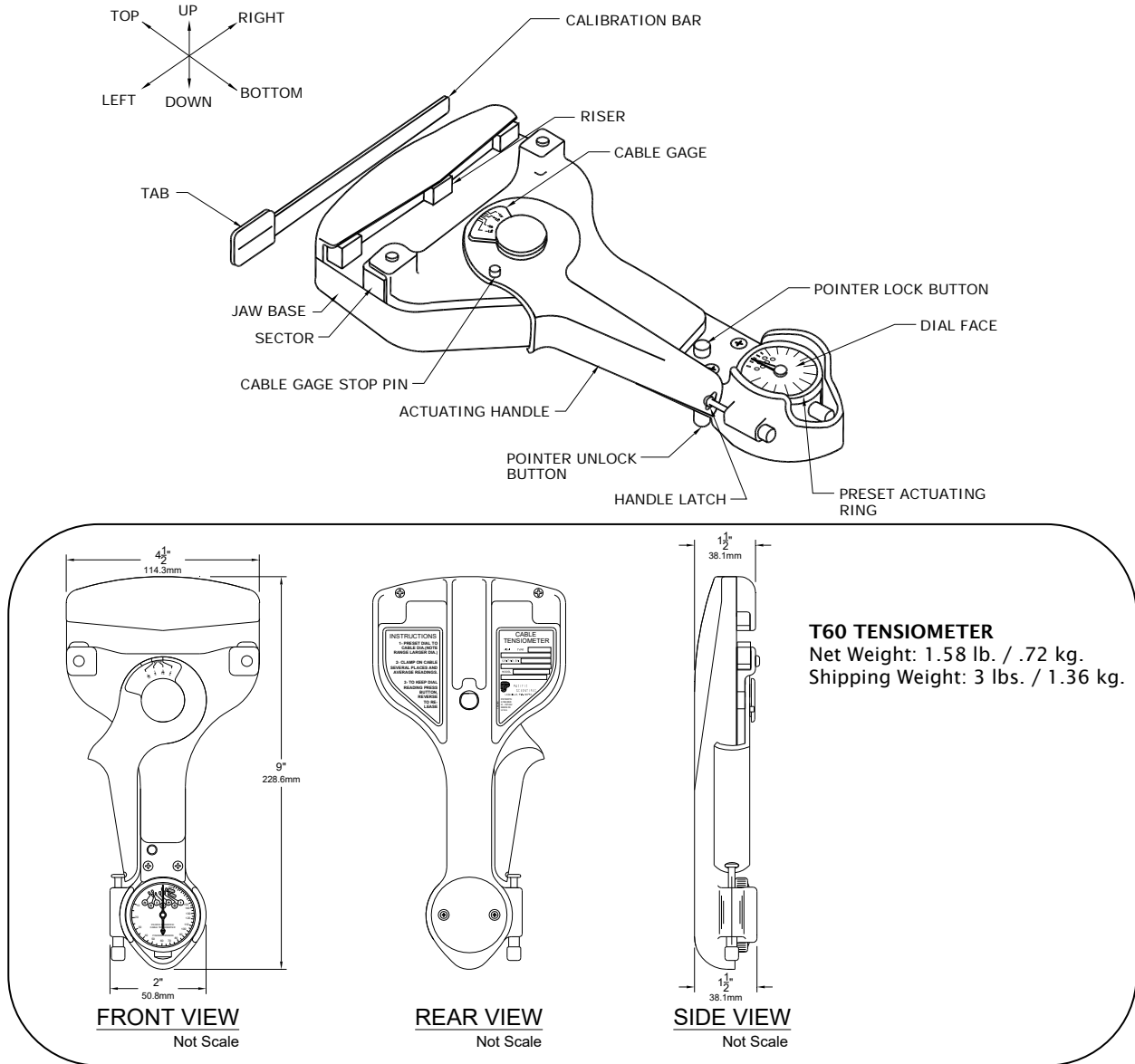

Figure 1- Cable Tensiometer, Typical

SECTION IV

OPERATION INSTRUCTIONS

4-1. GENERAL INSTRUCTIONS - Each time the instrument is removed from its case for use check the serial number on the nameplate to ascertain that it agrees with the serial number on the calibration bar. Before using the instrument check the calibration by means of the calibration bar. (See paragraph 4-9.)

Warning: Cable Tensiometers should not be used for adjusting the rig load in a cable system where an automatic cable tension regulator is installed. All such cable systems should be rigged by adjusting them so that the pointer on the cable tension regulator scale indicates the correct number based on the surrounding temperature as indicated on the chart provided by the aircraft Maintenance Manual. The Tensiometer may be used to check the tension so obtained, but it must be remembered that the actual cable tension will vary from the nominal depending on the errors in the instrument itself, manufacturing tolerance of springs in the regulators, rate of the regulator spring, and condition of the control cable. Cable tension readings taken on a regulated control system therefore can be misleading and can result in damage through improper rigging.

4-2. OPERATING INSTRUCTIONS - Either the right- or left-hand may be used to operate this instrument. The handle latch retains the actuating handle. The latch is automatically released when the actuating handle is squeezed. To re-latch the actuating handle, the handle must be squeezed firmly against the side of the Tensiometer and the handle latch pushed up from the bottom against its spring load and held in the extended position while the actuating handle is slowly released against the handle latch. The latch end will be retained in the detent socket provided in the actuating handle.

Note: When operating the instrument handle, the handle should never be allowed to snap open; it should be released gradually, allowing the unit to clamp firmly on the cable.

4-3. MEASURING CABLE DIAMETERS

Figure 2- T60 Cable Diameters

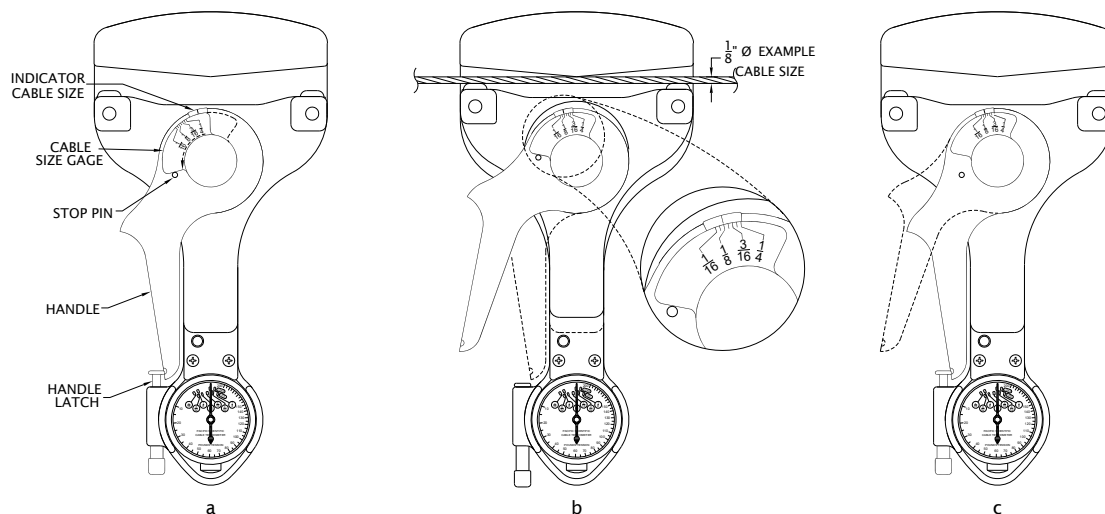

- With the actuating handle in the latched position, move the cable size gage to the left against the cable stop pin. See Figure 2a.
- Release handle latch by squeezing the actuating handle. Retain the actuating handle unlatched against the side of the Tensiometer. Place the instrument on the cable, making certain that the cable is squarely aligned in the jaws and resting on the sectors and riser block. Care should be taken that the cable is resting flat against the jaw base. Slowly release the actuating handle, allowing the sectors to slide up and grip the cable. Remove all restraint from the actuating handle. See figure 2b.
- Remove Tensiometer from the cable by returning the actuating handle to the latched position. The black line opposite the position on the cable size gage indicates the cable diameter. See figure 2c.

Warning: When re-latching actuating handle, verify that the latch is positioned in the detent socket before releasing the handle. If this is not done, the handle will be allowed to snap open with possible personal injury.

4-4. TAKING CABLE TENSION READINGS, TYPE C8

- a. Preset dial by rotating the knurled rim of the dial indicator until the pointer is directly over the line corresponding to the cable diameter. (See Figure 3a)

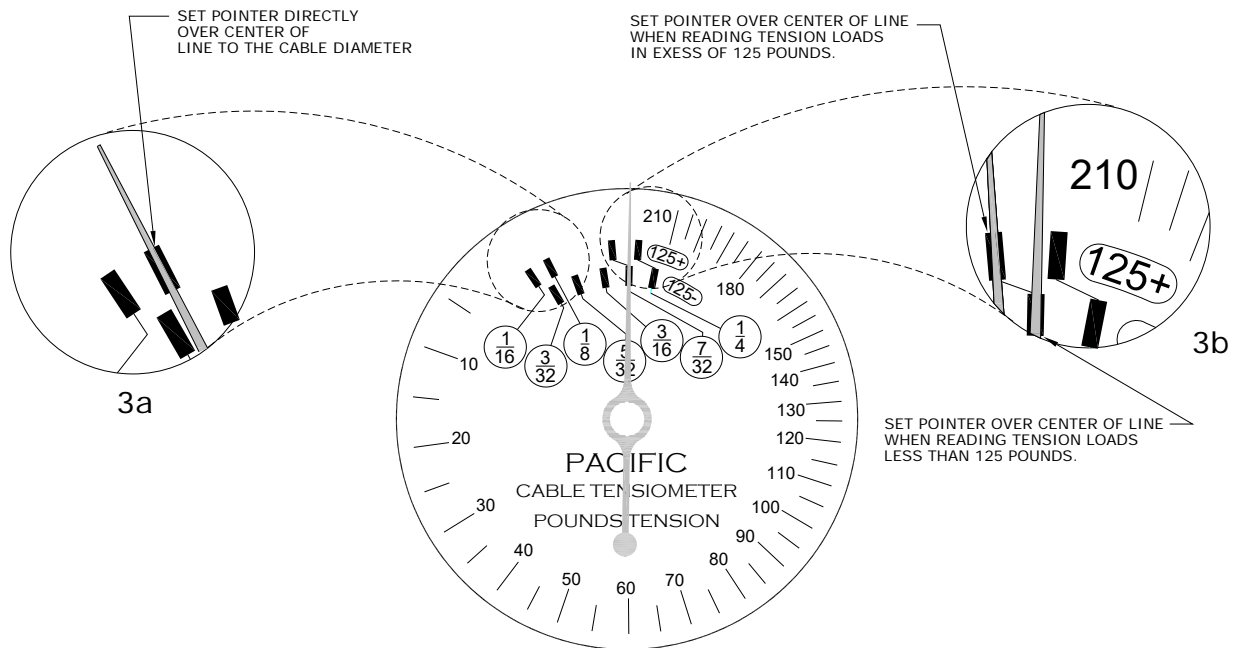

Figure 3- Preset Instructions, Type C8

Note: Shown figure is for reference purpose, actual dial may vary.

NOTE 1: An examination of the dial will indicate that for the larger size cables there are two rows preset lines. One row is identified by 125-; the other row is identified by 125+. When measuring tensions below 125 pounds use the lower line; when measuring tensions in excess of 125 pounds use the high line. (See Figure 3b)

NOTE 2: When used the cable coated type, you shall preset the dial in cable's O.D. including coated insulation. For example if your 5/32" coated cable has an OD of 7/32" then the dial pointer preset shall be in the 7/32" mark and not on the 5/32". To obtain the cable OD measurement you may use the instrument's integrated cable size gauge and procedure sec. 4-3.

- b. Release the handle latch by squeezing the actuating handle. Retain the actuating handle unlatched against the side of the Tensiometer. Place the instrument on the cable, making certain that the cable is squarely aligned in the jaws and against the jaw base. Slowly release the actuating handle, allowing the sectors to slide up and grip the cable. Remove all restraint from the actuating handle.
- c. With the Tensiometer clamped on the cable the tension is read directly by the pointer position on the dial face.
- d. To remove the Tensiometer compress the actuating handle firmly against the side of the Tensiometer and latch the handle in position with the handle latch.

4-5. **TAKING TENSION READINGS, TYPE C9** - The Type C9 cable Tensiometer is used in the same manner as the Type C8 with the following exception: the larger size cables have two rows of preset squares, one row identified by 250-, the other row identified by 250+. When measuring cable tensions below 250 pounds use corresponding squares in the row indicated by 250- and conversely, for the opposite condition, use 250+.(See Fig. 3.5)

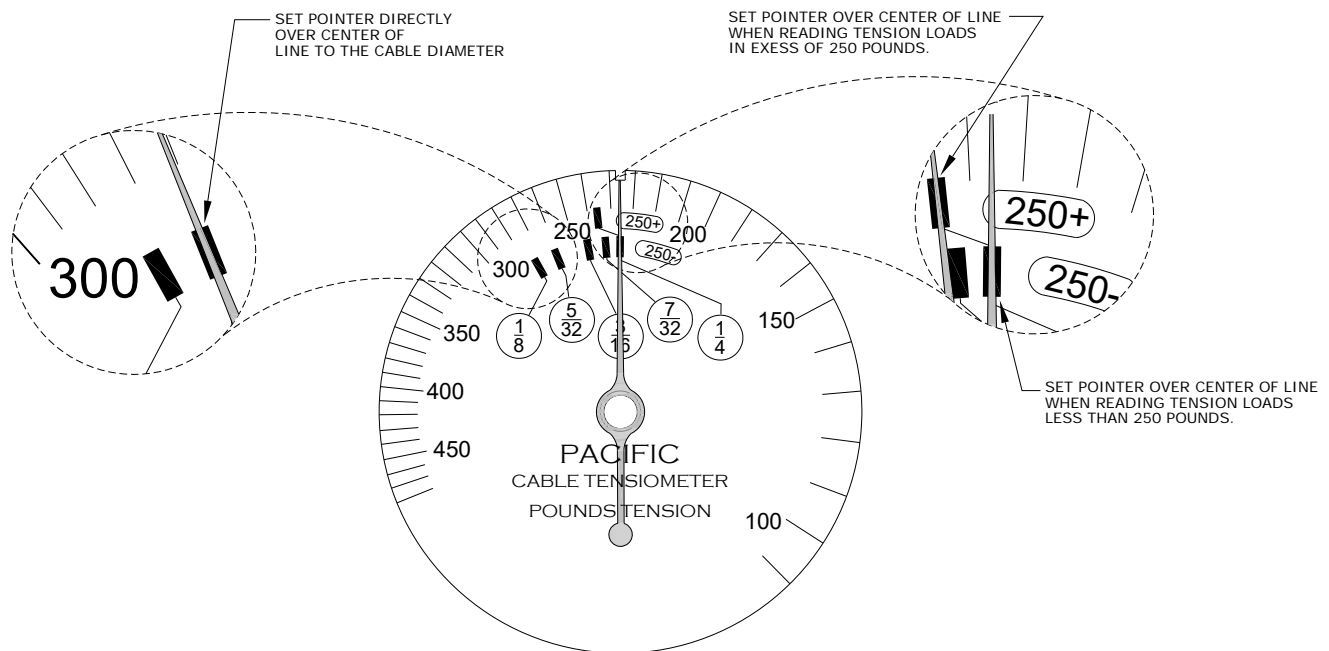

Figure 3.5- Preset Instructions, Type C9

Note: Shown figure is for reference purpose, actual dial may vary.

4-6. **DIFFICULT LOCATIONS** - When taking readings among closely grouped cables or in awkward or blind locations, let the actuating handle remain open with the instrument clamped on the cable. While in this position, press the pointer lock button down. Remove the Tensiometer by compressing the actuating handle against the case and remove. The dial indicator pointer will be locked in a position directly over the tension reading obtained on the cable. To release this reading, press up on the pointer unlock button.

Note: Do not attempt to take cable tension readings with the pointer lock button pressed down. If the pointer lock button is depressed during a tension reading, a false reading will result due to the friction of the brake mechanism.

4-7. **ACCURACY** - Because of the uneven surface of stranded cable, slight variations in reading may occur on the same cable at the same tension. This is especially true of 5/32-inch diameter cable and larger. To obtain the greatest possible accuracy, take three to five readings at slightly different locations on the cable. Average these readings to obtain the maximum degree of accuracy. Is consider “out of tolerance” if not meet with the specification of following table 2:

Table 2- T60 Accuracy Tolerance

MODEL	RANGE (LBS-TENSION)	ACCURACY (+/-)
T60-C8	10-200	±5% of indicator or one minor division from dial scale whichever is greater, values taken from dial scale average reading.*
T60-C9	150-450	±5% of indicator or one minor division from dial scale whichever is greater, values taken from dial scale average reading.*

***Due principally to the uneven surface of the stranded cables, slight variations in readings may occur on the same cable at the same tension. If closest possible accuracy is desired take three or five readings at slightly different locations on the cable and average them.**

4-8. TYPE OF CABLE - The cable Tensiometer is calibrated for use on standard, multiple-strand, aircraft cable of 7 x 7 or 7 x 19 stranding in sizes of 1/16, 3/32, and 7 x 19 stranding for 1/8 through 1/4 inch diameter on cable. Do not attempt to use the cable Tensiometer on cables of a different construction. Cables construction and specification in accordance with MIL-DTL-83420 Type I, general specification for flexible wire rope for aircraft control cables. See TABLE 5 for British Equivalent. The Tensiometer instrument shall be calibrated on the same type of cables on which the Tensiometer instrument will be used (such as coated cables used externally on helicopters). The T60 series cable Tensiometer are standard calibrated on Flexible, wire rope, for aircraft control cables. Flexible cables, either coated or non-coated, shall conform to MIL-DTL-83420. Most Aircraft systems use the Flexible cable. Some aircraft, (A-10 and F-15), use both Flexible and Non-Flexible cables. A Tensiometer instrument calibrated on Flexible cable will not give accurate tension readings when measuring Non-Flexible cable. Non-Flexible cables shall conform to MIL-DTL-87161, (Supersedes MIL-W87161 & MIL-W-5693). Again, the Tensiometer instrument shall be calibrated on the same type of cables on which the Tensiometer instrument will be used.

4-9. USE OF CALIBRATION BAR - A Calibration bar is supplied with each Tensiometer. This provides an immediate means of checking the accuracy of the instrument while in use. The calibration bar has been carefully checked to read the load marked on the identification tab. The identification tab also carries the serial number of the instrument for which that particular calibration bar is provided. To check calibration proceed as follows:

- a. Preset the indicator dial face to the smallest cable size listed, 1/16 for C8 and 1/8 for C9, 3cwt for C8 and 10cwt for C9 British models.
- b. Grasp the calibration bar identification tab in the left hand.
- c. Place the bar in the instrument with the identification tab facing the user, and the right end of the bar flush with the edge of the instrument. See Figure 4.

Figure 4- Calibration Bar Instruction

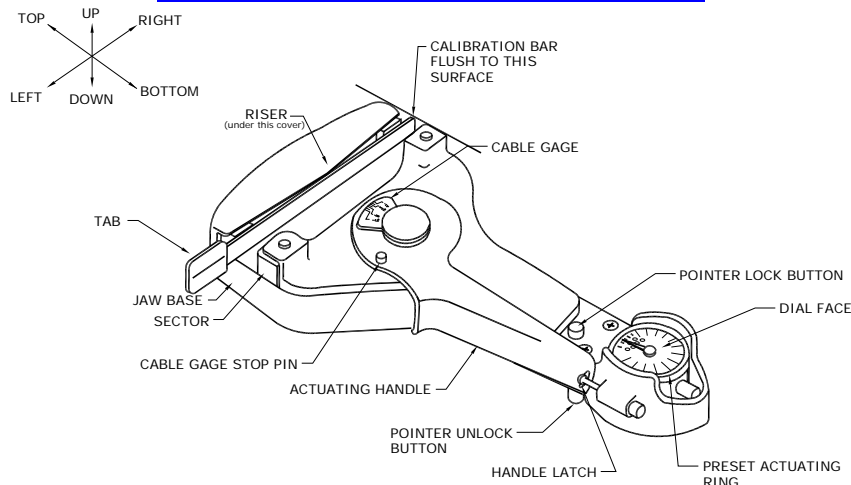

- d. Slowly release the actuating handle, allowing the jaws to grip the calibration bar. Note the reading on the dial indicator. The reading obtained in this manner should correspond with the reading marked on the identification tab within +/- 2 % of the value marked. The Tensiometer's serial number shall be marked on the bar.

Caution: The TEST BAR shall be placed flush against the riser faces such that the faces of the risers are parallel with the test bar.

4-10. OVERLOAD - The cable Tensiometer is a durable precision instrument and cannot be damaged by use on cables loaded in excess of the amount indicated by the dial on the Tensiometer.

SECTION V

PERIODIC INSPECTION, MAINTENANCE, AND LUBRICATION

5-1. GENERAL - No periodic inspection, maintenance, or lubrication is required for cable Tensiometers. As a matter of general practice, the instrument should be kept clean at all times. Particular attention should be paid to the two sectors and the riser block to see that they are always free from foreign matter. The instrument as shipped by the manufacturer has been lubricated. In the event that repairs are made as outlined in Section VI, lubrication should be accomplished as listed in table 3. Method of application is a light wipe.

*Explanation: D. C. #33: Dow Corning Grease #33 fluid type or equivalent to NATO G-395 fluid type per MIL-PRF-81322.

[Table 3- Lubrication Chart](#)

FIG. 6 INDEX NO.	LUBRICATION*	LOCATION
20	D.C. #33	Both sides
23	D.C. #33	On OD of pins and flat face
26	D.C. #33	ID and OD
29	D.C. #33	OD
32	D.C. #33	OD
38	D.C. #33	OD
40	D.C. #33	OD

SECTION VI

TROUBLE SHOOTING

6-1. GENERAL - The instrument will be free from trouble such as would be caused by nominal use. The instrument, however, can be damaged by mistreatment and improper usage. If a detail part of the instrument becomes damaged or broken, disassemble the instrument in the order of the index numbers indicated on the exploded view, Figure 6. All detail parts of the instrument are so integrated that in order to perform a disassembly operation it is necessary that disassembly be started with index number 1 and continued in numerical sequence. The only exception to this is the latch mechanism (37 through 40, Figure 6). Reassembly is the opposite of disassembly. Whenever the instrument has been disassembled, it must be recalibrated. (See Section VII.)

6-2. SERVICE TROUBLES AND REMEDIES - (See table 4) a listing of common troubles together with their probable causes and remedies is presented as a trouble-shooting chart, table 4.

[Table 4- Trouble Shooting Chart](#)

TROUBLE	PROBABLE CAUSE (See Figure 6)	REMEDY
Tensiometer reads high	Faulty dial indicator (35)	Replace dial indicator and calibrate
Tensiometer reads low	Weak trigger spring (29)	Replace trigger spring and calibrate
	Dirt and foreign matter between frame (41) and sectors (24)	Clean and reassemble
	Worn out sectors (24) or riser Block (5)	Replace sectors and riser block; then calibrate
Pointer lock will not function	Faulty dial indicator (35)	Replace dial indicator and calibrate
	Switch spring (30) broken	Replace switch spring and calibrate
Handle latch will not lock handle in close position	Handle latch spring (39) weak or broken	Replace latch spring. Do not calibrate

SECTION VII

CALIBRATION

- 7-1. EQUIPMENT REQUIRED** - Calibrating the cable Tensiometer it will be necessary to have aircraft cables of various sizes and a method of accurately loading these cables with a range of loads from 10 to 450 pounds.
- 7-2. DISASSEMBLY PRIOR TO CALIBRATION** - (See Figure 6) Disassemble the instrument following the order of the index numbers, starting with index number 1 down through and including index number 10.
- 7-3. CALIBRATION** - Calibrate the instrument as follows:
- a. Move post shaft (12) up and down and check for free movement and that the pointer returns to the same position on the dial indicator each time.
 - b. If binding or erratic indication occurs disassemble the instrument further to ascertain the cause.
 - c. Check for free movement of sectors (24). There shall be 0.015-inch maximum clearance between sectors (24) and frame (41). This is controlled by number of washers (25) placed under the sectors (24).
 - d. Place a washer (8) on each top pin of frame (41). Position mainspring (7) and secure with clips (6).
 - e. Check that post shaft (12) just or almost contacts mainspring (7) and that mainspring does not deflect shaft post and consequently pointer of dial indicator (35). If necessary, adjust position of post shaft (12) on indicator shaft (13) by loosening setscrews (11) to obtain this condition. Be careful not to get a false position. This can occur if indicator shaft (13) is not bottomed in dial indicator (35).
 - f. Position risers block (5). The riser block should not deflect the mainspring (7). If it does, select a riser block with a low tolerance.
 - g. Place clips (4) on the lower pins of frame (41). Between the pins and the top of the clip place a 0.010-inch shim (3) on each side of the instrument.
 - h. Drop spring (10) onto shaft (13) and secure with screw (9).
 - i. Check for a symmetrical bite. On a pre-loaded 7/32" cable, start to take a tension reading but do not remove all restraint from handle. With the Tensiometer in this position, wiggle the cable with free hand to determine that the resistance to movement is the same at both sectors (24). Add shims (3) as necessary to balance bite. Add shims to obtain lower readings and remove shims to obtain higher readings. Use shims that are 0.003 or 0.005 inch thick and place them on the bottom of the pins. After the bite is balanced, place equal shim thickness on each side of the instrument for subsequent calibration.
 - j. Proceed with calibration by preloading the 7/32" cable, with a load equal to the high end of the instrument range. The high end is 200 lbs. for the type C8 and 450 lbs. for the type C9. Measure the tension and add or remove shim (3) as necessary to make indicator read between 190-195 lbs. for Type C8 and between 430-440 lbs. for the Type C9. Remember, the addition of shims (3) makes lower readings. On the other hand, the remove of shims (3) makes higher readings. Try to set as close as possible to 200 lbs. for type C8 and 450 lbs. for type C9.
 - k. Proceed to verify calibration by preloading the 7/32" cable with a load equal to the low end of the instrument. Measure tension and add or remove shims (3) as necessary to make indicator read between 75-80 lbs. for Type C8 and between 142-150 lbs. for the type C9.

- l. Repeat steps *i* and *j* for 1/16" cable on Type C8 and 1/8" cable on Type C9, to improve indicator accuracy to +/- 5 % (If closest possible accuracy is desired take three to five reading at slightly different locations on the cable and average them). On step *j* for 1/16" & 1/8" cable on Type C8 the low end is 10 lbs. and the desired indicator read between 9-15. Do not remove the 0.010 inch shims from the top of the frame pins. After this, the unit shall make linearity for all cables and tension ranges.
- m. Replace cover (2) and secure with screws (1).
- n. Preset the indicator dial to the smallest cable size. Measure the load required to deflect the calibration bar. Remove the load marked on the identification tab and mark the new value indicated on the Tensiometer.

Note: Due principally to the uneven surface of the stranded cables, slight variations in readings may occur on the same cable at the same tension. If closest possible accuracy is desired take three or five reading at slightly different locations on the test area of the cable and average them. It is considered a unit to be 'out of calibration' when the average reading is more than ± 5% of indicator or one minor division whichever is greater.

7-4. INDICATOR CABLE SIZE - To re-establish the accuracy of the indicator cable size , proceed as follows:

- a. Remove existing mark on center pin washer (17) with a fine file.
- b. With handle in locked position, rotate indicator cable size (16) counterclockwise until it contacts stop on handle assembly (19). See figure 2 for reference.
- c. For C8 model, set at 100 lbs. on cable 1/16, for C9 model, set at 150 lbs. on cable 1/8, clamp the Tensiometer on a cable.
- d. Return handle to lock position.

Note: In next step, do not move the indicator cable size (16).

- e. Mark center pin washer (17) with a scribe opposite on known diameter (1/16 or 1/8) on indicator cable size.

Table 5- STD Cable Size to British (CWT) Cable Size Equivalents

INCHES	BRITISH CWT
1/16"	3
3/32"	5
1/8"	10
5/32"	15
3/16"	25
7/32"	35
1/4"	45
9/32"	70
5/16"	80

SECTION VIII

GROUP ASSEMBLY PARTS LIST

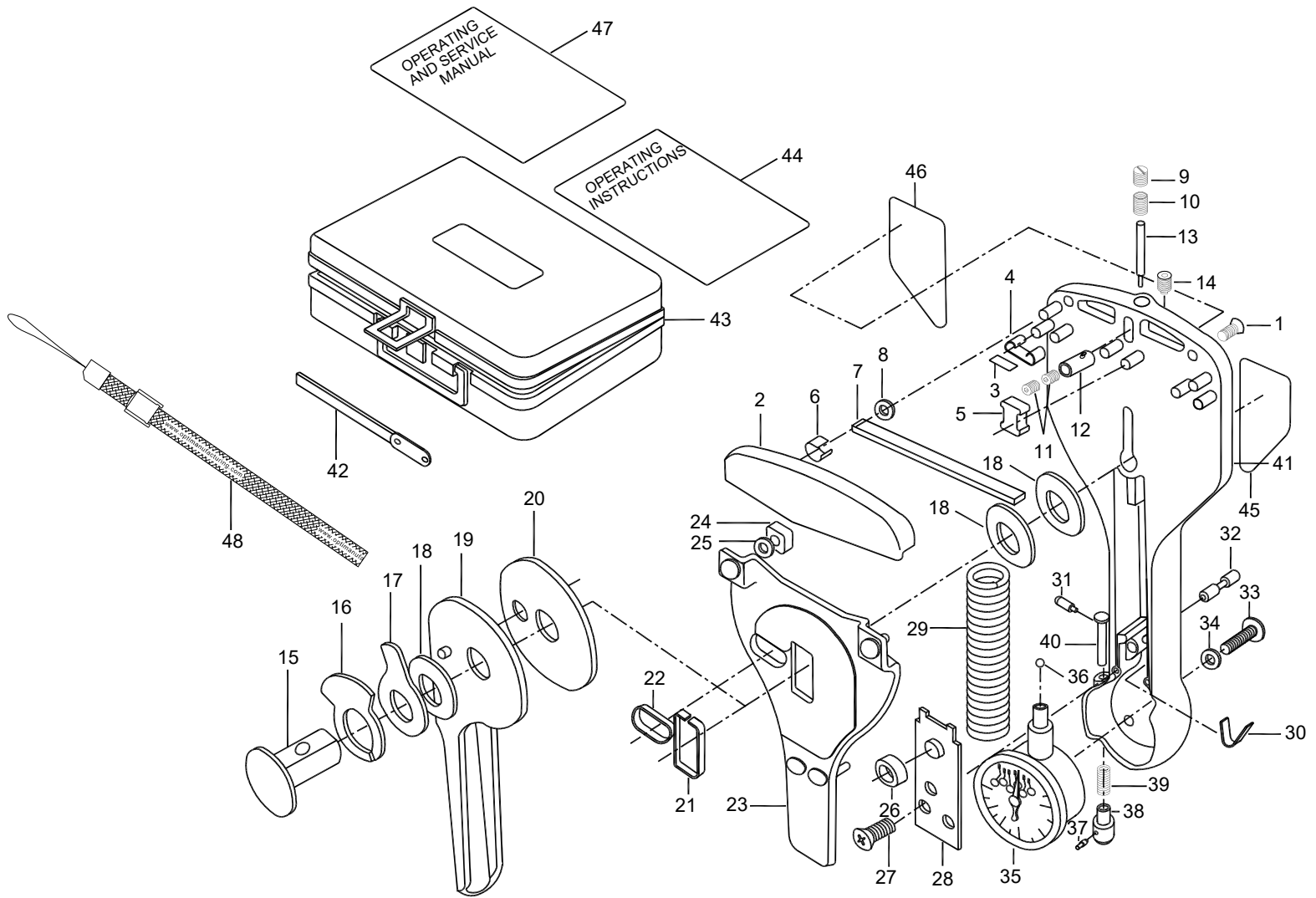

Figure 6- Cable Tensiometer, Type C8 and C9

Table 6 Part List

FIG. & INDEX NO.	PART NUMBER	DESCRIPTION	UNITS PER ASSY	USABLE ON CODE
6-	T60-1001-C8-1A	TENSIOMETER ASSY, Cable	REF.	A
	T60-1001-C9-1A	TENSIOMETER ASSY, Cable	REF.	B
	T60-1002-C8-00	TENSIOMETER ASSY, Cable-British Model	REF.	C
	T60-1002-C9-00	TENSIOMETER ASSY, Cable-British Model	REF.	D
-1	COML # 0901100-55	. SCREW, 4-40 x ½ inch long Phillips oval head	2	
-2	T60012	. COVER, Head	1	
-3	T5033-3	. SHIM, Clip, 0.003 inch thick	A/R	
	T5033-5	. SHIM, Clip, 0.005 inch thick	A/R	
	T5033-10	. SHIM, Clip, 0.010 inch thick	A/R	
-4	T5018	. CLIP	2	
-5	T5013	. BLOCK, Riser	1	
-6	T5020	. CLIP, Mainspring	2	
-7	T5019-1	. MAINSPRING	1	A,C
	T5019-3	. MAINSPRING	1	B,D
-8	T5034	. WASHER	2	
-9	T60032	. SCREW, Spring adjusting	1	
-10	T541	. SPRING, Follower riser	1	
-11	COML # 0901100-48	. SCREW, 4-40 x 3/16 inch long hexagonal socket head cup point black oxide	2	
-12	T60031	. POST, Shaft	1	
-13	T60026	. SHAFT, Indicator	1	
-14	COML #0901100-99	. SCREW, 10-32 x 5/16 inch long socket head	1	
-15	T60018	. PIN, Center	1	
-16	T60022	. INDICATOR, Cable size	1	A,B
	T60058	. INDICATOR, Cable size-British Model	1	C,D
-17	T60019	. WASHER, Center pin	1	
-18	T60068	. WASHER, Spacer	3	
-19	T60014-1	. HANDLE ASSY	1	
-20	T60037	. WASHER, Spacer	1	
-21	T60070	. LINER, Pin	1	
-22	T60071	. LINER, Roller	1	
-23	T60023	. YOKE ASSY	1	
-24	T537	. SECTOR	2	
-25	T60052	. WASHER	6	
-26	T60030	. ROLLER, Guide yoke	1	
-27	AN531-4RF6	. SCREW, 4-40 X 3/8" thread cutting Phillips head 82° C sunk	2	
-28	T60008	. PLATE	1	
-29	T60050	. SPRING, Trigger	1	
-30	T60035	. SPRING, Switch	1	
-31	T60048	. PIN, Switch spring	1	
-32	T60006	. SHAFT, Switch	1	
-33	MS35207-203	. SCREW, Indicator, 2-64 x 1/4" long round head Phillips Recess UNF-2A	2	

FIG. & INDEX NO.	PART NUMBER	DESCRIPTION	UNITS PER ASSY	USABLE ON CODE
-34	AN960-3L	. WASHER	2/4	
-35	T60059	. INDICATOR, Dial	1	A
	T60057	. FACE, Dial-British Model	1	A,C
	T60060	. INDICATOR, Dial	1	B
	T60067	. FACE, Dial-British Model	1	B,D
-36	COML #0908100-03	. BALL BEARING, 0.093 dia cres	1	
-37	COML #0913200-02	. PIN, Groove type # 4, 1/16 dia x 5/16 inch long	1	
-38	T60025	. CAP, Handle lock	1	
-39	T60028	. SPRING, Handle latch	1	
-40	T60024	. PLUNGER, Handle lock	1	
-41	T60021	. Frame Assy	1	
	T60074 (not shown)	. . BEARING	1	
	T60011	. . FRAME	1	
	T60033	. . PIN-FRAME	8	
-42	T60054	. TEST BAR ASSY, Calibrating	1	
	T60053	. . TAG	1	
	T5036	. . TEST BAR	1	
	MS20470AD2-3	. . RIVET, 1/6 dia x 3/16 inch long	1	
-43	T5138-60	. CARRYING CASE ASSY	1	
	0922100-88	. . BLACK CASE	1	
	T5185-51	. . INSERT CUSHION	2	
	T5184-01	. . CUSHION, T60	1	
-44	WI-CU-002	. . INSTRUCTIONS SHEET, Operating	1	A, B
	WI-CU-003	. . INSTRUCTIONS SHEET, British Model	1	C, D
-45	T60039	. LABEL, INSTRUCTIONS	1	
-46	T60040	. LABEL, NAMEPLATE	1	
-47	SOP-TN-002	. . OPERATION AND SERVICE MANUAL	1	ALL
-48	T60007	. . WRIST BAND	1	ALL

. Denotes non-subassembly or final component part.

.. Denotes subassembly parts.

OPTI Manufacturing Corp.

Road 992 Km 0.3. Mata de Plátano Industrial Ward,
Luquillo, PR 00773-2581 USA

Phone: (787) 889-2285 / Fax: (787) 889-2805 fax

Copyright©. OPTI Manufacturing Corp. All Rights Reserved

Point of Contacts:

General info: info@optimanufacturing.com

Sales/Shipment: sales@optimanufacturing.com

Technical Support/RMA is: jorge@optimanufacturing.com

For the latest revision of this manual, refer to our website.

<http://www.optimanufacturing.com>

