

INSTRUCTION FOR USE OF PACIFIC CABLE TENSIO METER TYPE T60

PREPARATION FOR USE - The cable Tensiometer is shipped by the manufacturer in its own carrying case and is ready for use, for avoid damage on common use, the operator shall be use the Wrist Band adjustable. Each time the cable Tensiometer is used it shall be removed from the case and the serial number stamped on the nameplate checked against the serial number on the tab of the calibration bar.

IDENTIFICATION

PACIFIC Type T60-1001-C8-00 Tensiometer USAF equivalent – **Type C8**.
Range: 10–200 lbs.

PACIFIC Type T60-1001-C9-00 Tensiometer USAF equivalent – **Type C9**.
Range: 150 – 450 lbs.

GENERAL INSTRUCTIONS

BEFORE USING INSTRUMENT – Study diagram, see below Figure 1, in order to become familiar with nomenclature and part orientation.

EITHER THE RIGHT OR LEFT HAND may be used to operate this instrument.

ACTUATING HANDLE is retained by Handle Latch. This Latch is automatically released when the Actuating Handle is squeezed. To relatch the Handle, the Actuating Handle must be squeezed firmly against the side of the Tensiometer and the Handle Latch pushed up from the bottom and held in the extended position while the Actuating Handle is slowly released against the Handle Latch. The Latch end will be retained in the detent socket provided in the Actuating Handle.

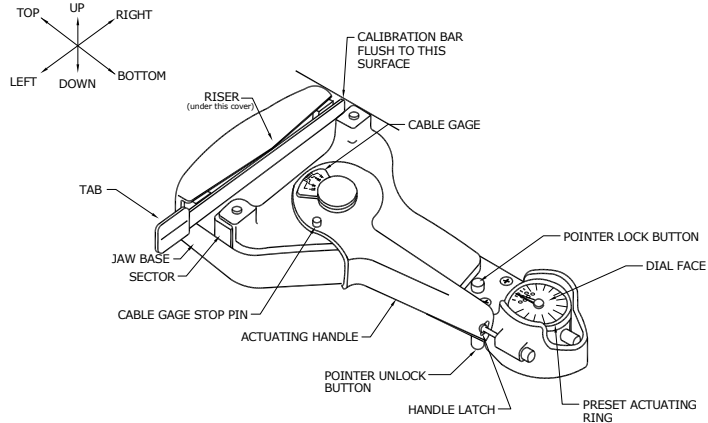

Figure 1 Cable Tensiometer, Typical

WARNING:

When re-latching actuating handle it must be determined that the latch is in the detent socket before releasing the handle.

IN ACTUATING THE INSTRUMENT HANDLE to obtain cable tension readings, the HANDLE SHOULD NEVER BE ALLOWED TO SNAP OPEN. IT SHOULD BE RELEASED GRADUALLY, ALLOWING THE UNIT TO CLAMP FIRMLY ON THE CABLE.

DO NOT ATTEMPT to take cable tension readings with the Pointer Lock Button depressed (down). See Fig. 1. If the Pointer Lock Button is depressed during tension reading, a false reading will result due to the friction of the brake mechanism.

OVERLOAD – The T60 Tensiometer will not be damaged when used on cables loaded in excess of the amount indicated by the dial on the Tensiometer.

FOR GREATEST ACCURACY – Due to the uneven surface of stranded cable, slight variations in reading may occur on the same cable at the same tension. This is particularly true of 15 CWT diameter cable and larger. To obtain the greatest possible accuracy, it is recommended that three to five readings be taken at slightly different locations on the cable and these values averaged. This will tend to eliminate the effect of cable variation and obtain the maximum degree of accuracy.

TYPE OF CABLE –The Tensiometer instrument shall be calibrated on the same type of cables on which the Tensiometer instrument will be used (such as coated cables used externally on helicopters). The T60 series cable Tensiometer are standard calibrated on Flexible, wire rope, for aircraft control cables. Flexible cables, either coated or non-coated, shall conform to **MIL-DTL-83420**. Most Aircraft systems use the Flexible cable. Some aircraft, (A-10 and F-15), use both Flexible and Non-Flexible cables.

A Tensiometer instrument calibrated on Flexible cable will not give accurate tension readings when measuring Non-Flexible cable. Non-Flexible cables shall conform to **MIL-DTL-87161**, (Supersedes MIL-W87161 & MIL-W-5693). Again, the Tensiometer instrument shall be calibrated on the same type of cables on which the Tensiometer instrument will be used.

WARNING: USE OF TENSIO METER ON CABLE SYSTEMS EQUIPPED WITH CABLE TENSION

REGULATORS. Cable Tensiometer should NOT be used for adjusting the rig load in a cable system where an automatic cable tension regulator is installed. In all cases, such cable systems should be rigged by adjusting them so that the pointer on the cable tension regulator scale indicates the correct number based on the surrounding temperature, as indicated on the chart provided in the Airplane Service Manual. The Tensiometer may be used to check the tension so obtained but it must be remembered that the actual cable tension will vary from the nominal, depending upon the errors in the instrument itself, manufacturing tolerance of springs in the regulators, rate of the regulator spring, and condition of the control cable. Cable tension readings taken on regulated control systems by means of a Tensiometer could, therefore, be misleading.

TO TAKE READINGS

1. To Measure Cable Diameter:
 - a. With the Actuating Handle in the latched position, move the Cable Gage to the left against the Cable Gage Stop Pin.
 - b. Release the Handle Latch by squeezing the Actuating Handle. Retain the Actuating Handle unlatched against the side of the Tensiometer. Place instrument on the cable, making certain that the cable is squarely aligned in the Jaws. Care should be taken that the cable is resting flat against the Jaw base. Slowly release the Actuating Handle, allowing the cable Jaw to slide up and grip the cable. Remove all restraint from the Actuating Handle.
 - c. Remove Tensiometer from the cable by returning Actuating Handle to the latched position. The cable diameter is indicated by the black line opposite a position on the Cable Gage.
2. To Take Tension Readings:
 - a. **TYPE C8** – To Pre-set Dial: Rotate knurled rim of pre-set dial until the pointer is directly over the line corresponding to the cable diameter (See Fig 2). With the dial properly aligned with the correct cable size, repeat step 1. b.
TYPE C9 – To Pre-set Dial: Rotate knurled rim of pre-set dial until the pointer is directly over the line corresponding to the cable diameter (See Fig 2). With the dial properly aligned with the correct cable size, repeat step 1. b.
 - b. To Read Cable Tension: With the Tensiometer clamped on the cable, the tension is read directly by pointer position on the Dial Face. To remove the Tensiometer, compress the Actuating Handle firmly against the side of the Tensiometer.

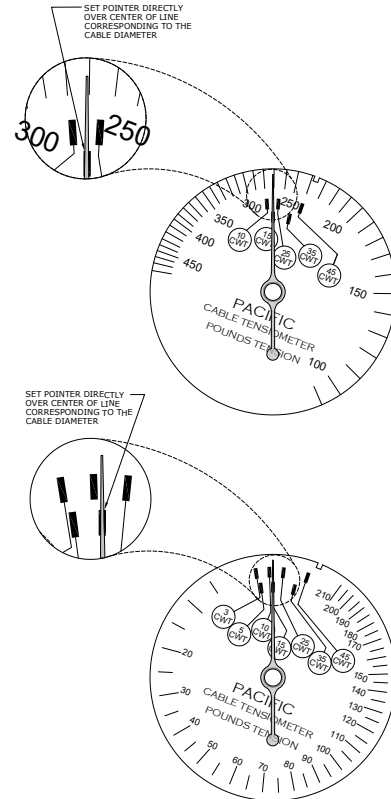

Figure 2 Preset Instructions Type C8 & C9 British

MANIPULATION FOR DIFFICULT LOCATIONS

In taking readings among closely grouped cables or in awkward or blind locations, let the Actuating handle remain open with the instrument clamped on the cable. With the instrument clamped in this position, press the Pointer Lock button down. Remove the Tensiometer by compressing the Actuating Handle against the side of the case and remove. The dial indicator pointer will be locked in a position directly over the tension reading obtained from the cable. To release this reading, press up on Pointer Unlock Button (See Figure 1).

USE OF CALIBRATION BAR

A Calibration Bar is supplied with each Tensiometer, providing an immediate means of checking the accuracy of the instrument on the job. This Bar has been carefully calibrated to read the load marked on the identification Tab. Careful attention should be paid to the position of the Bar in the instrument.

Locate as follows: Grasp the Calibration Bar Identification Tab in the left hand. Place the Bar in the instrument with the Identification Tab facing the operator (toward bottom of instrument). In this position, the calibration reading will be visible. Pre-set the dial to the smallest cable size noted; then slowly release the Actuating Handle, allowing the jaws to grip the Calibration Bar. Repeat several readings and average. The average thus obtained on the dial should correspond within (+/-) 2 percent of the value marked on the Identification Tab (Test Bar).

ADJUSTMENT AND REPAIR

If adjustment, repair or annual calibration is necessary, return the instrument to OPTI Manufacturing Corp. or utilize the T60 Operation and Service Manual shipped with each Tensiometer for reference. For return units under a warranty claim, please contact us first in order to obtain a Return Material Authorization (RMA#).



OPTI MANUFACTURING CORPORATION
Road 992 Km 0.3 Mata de Platano Industrial Ward
Luquillo, Puerto Rico 00773-2581 USA
Phone: (787) 889-2285 / Fax: (787) 889-2805
<http://www.optimanufacturing.com>
Sales/Shipments: sales@optimanufacturing.com
Technical Support/RMA: jorge@optimanufacturing.com
2014 Copyright© OPTI Manufacturing Corp. All Right Reserved